



AFINIA LABEL®



USER MANUAL  
**DLP-2200**  
**Semi-Rotary Machine**



[spiralbinding.com](http://spiralbinding.com)  
800-631-3572

Version 1.1

# TECHNICAL SPECIFICATIONS



## !!IMPORTANT!

*This unit has some parts which are capable of causing injury to those who work at them or come close to them e.g. blades, nip roller, rotary cylinders inside the rotary module.*

DLP-2200	
Media Width	100mm up to 250mm
Unwinder Roll Diameter	Up to 460mm
Lamination Roll Diameter	Up to 250mm
Max. Diecutting Width	230mm
Max. Diecutting Length	360mm
Cutting Dies	Flexible steel, from 130mm to 360mm
Max. Finished Label Rewind	400mm
Max. Waste Matrix Rewind	300mm

## **POWER REQUIREMENTS**

DLP-2200	100-240V~1Kw, 50/60Hz
----------	-----------------------

### **Environmental functioning and storage requirements**

Operating temperature: From 5°C to 35°C.

Storage temperature: From 5°C to 50°C.

## **HOW TO INSTALL THE AFINIA PRINTER**

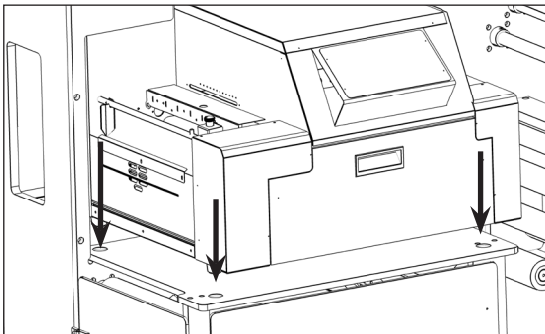

Place the printer on the plate, making sure to push the rubber feet into the holes.

**LAYOUT AND SIZE**

(2829)

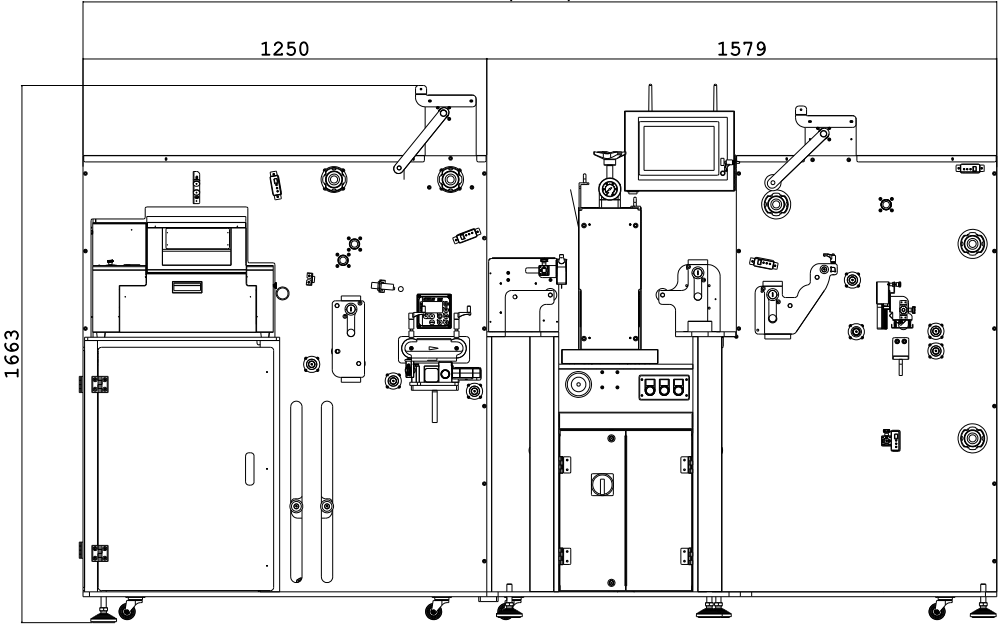

1323

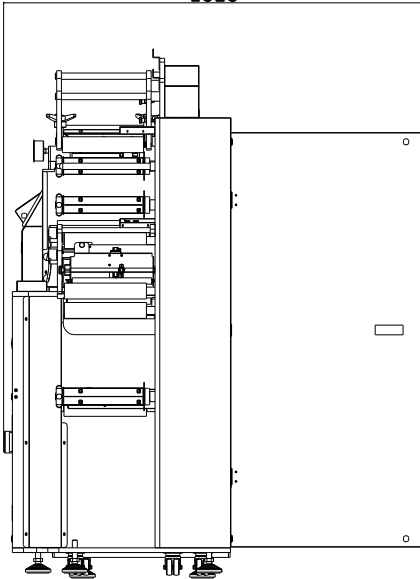

714

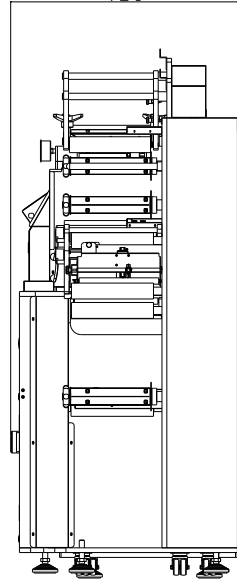

# MEDIA PATH

— Input roll  
— Liner roll

— Laminate roll  
— Waste roll  
— Trims

## Printer inline

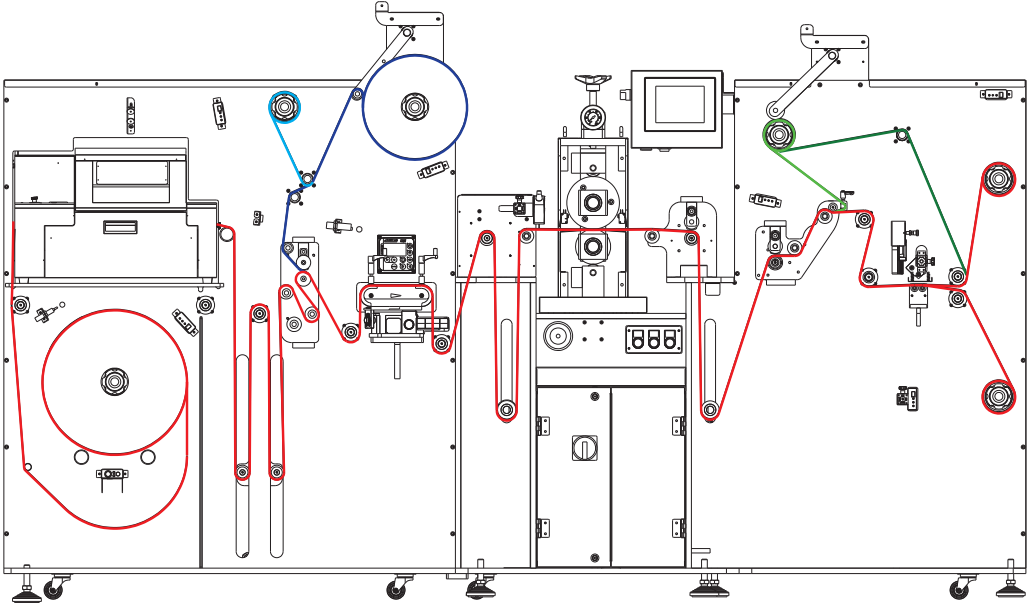

## Offline printed and unprinted roll

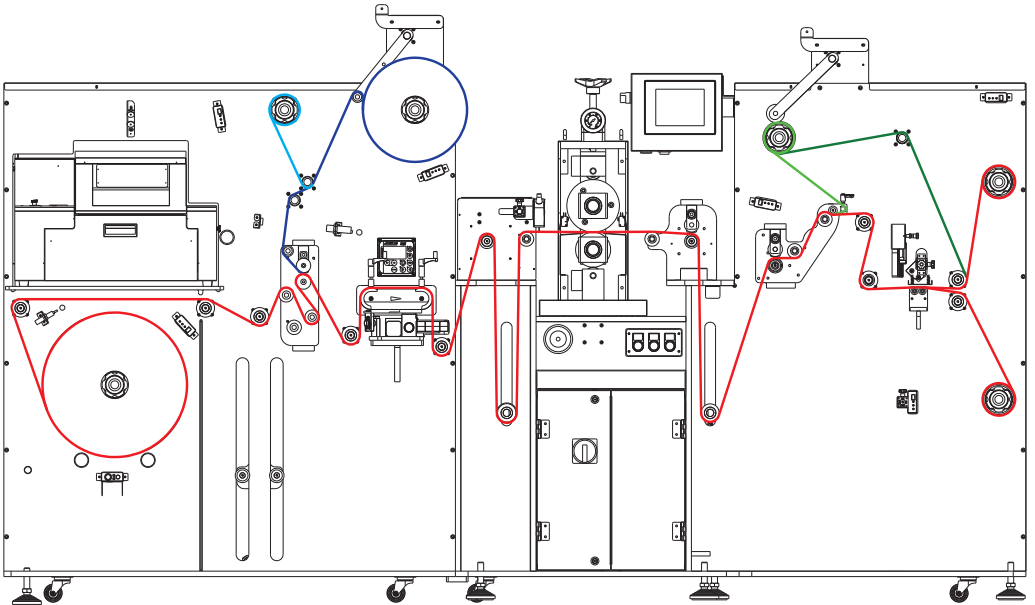

## **INSTALLATION**

Insert the two studs (on the rewinder module) into the slots located on the unwinder module. Then secure them together with four allen screws.

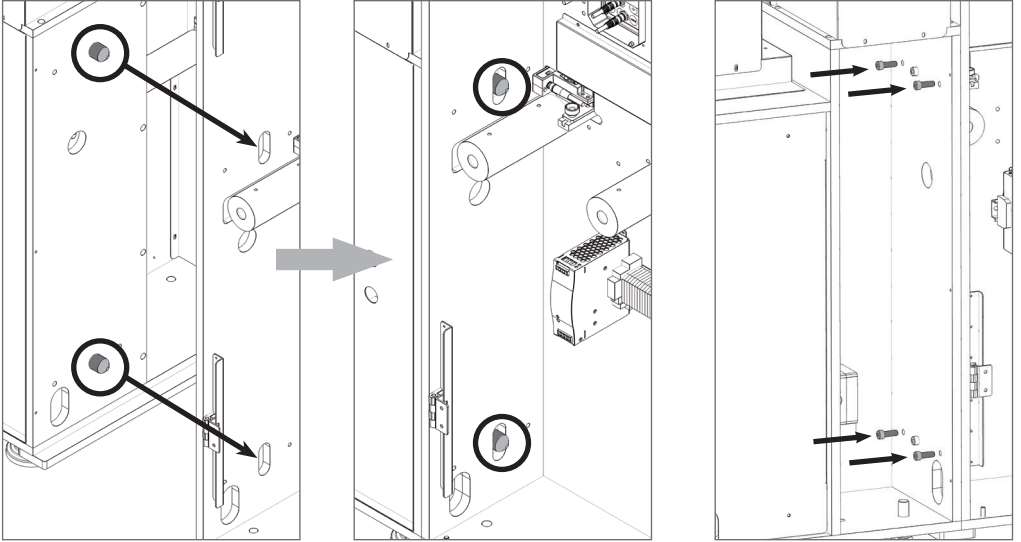

With a wrench, turn the bolt located on each foot left or right to raise or lower each module. This should help you to level the unit.

Clockwise > raises the unit

Counterclockwise > lowers the unit

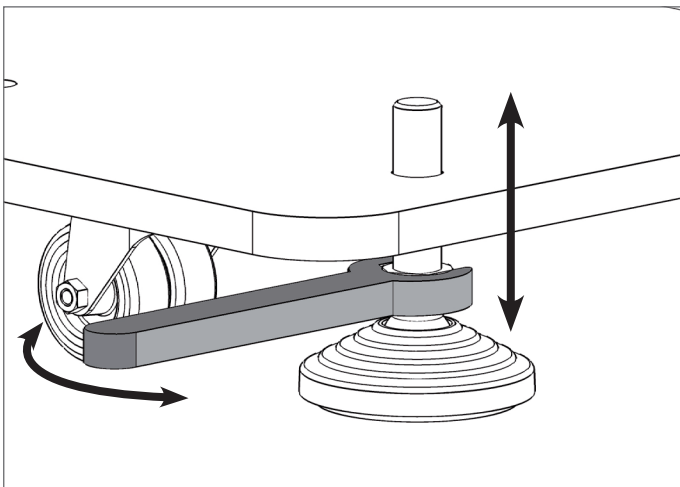

# OPERATION STEPS

## How to set the silencer

Silencer accessory is used to drastically reduce the noise generated by noisy self-wound lamination application.

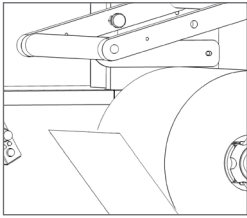

Load and fix the self-wound lamination roll on to the core holder.  
Pull the lamination end over the aluminium roller.

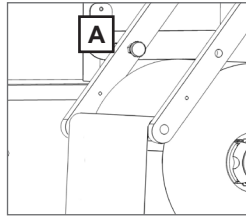

Use the knob (A) to unlock the silencer and let it fall down over the lamination roll.

## How to load the waste

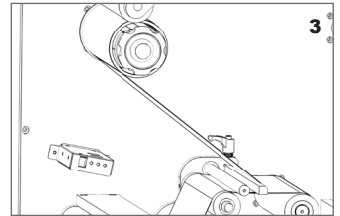
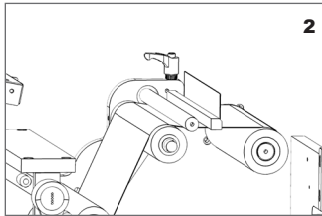
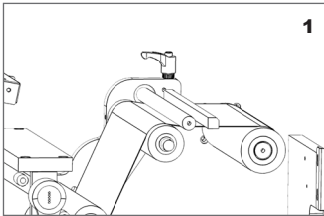

1. Turn the knob anti-clockwise to allow the waste removal arm to open and pass the media through the two rollers as shown in the photo.
2. Peel off the waste from the liner.
3. Attach the waste to the cardboard core loaded on to the core holder. Let the pressing roll fall down over the waste roll.

## How to set slitter module

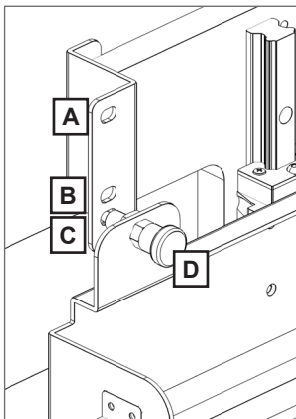

**Slitter module has 3 positions:**

- Upper position (A), the blades are lifted to allow the media loading;
- Middle position (B), slide the blade holders right and left to find the desired position where to perform the longitudinal cut. Tighten the screw to fix the blade holder in position;
- Lower position (C), the blades cut through the media.

To lock the module in A,B or C position use the knob (D)

## **How to use the splice table**

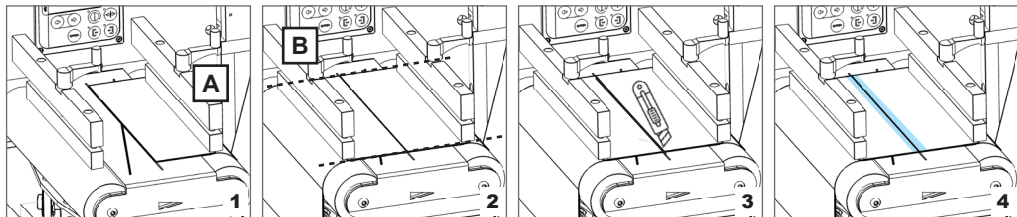

1. Screw the knob (A), the bracket fixes down the media already loaded through the unit.
2. Align the media from the new input roll just loaded to the media inside the unit and screw the knob (B). The bracket fixes down the new media too.
3. With cutter, cut the excess media along the lines.
4. With tape join both ends together (under and over the media) and release both knobs.

## **How to add or remove a blade holder**

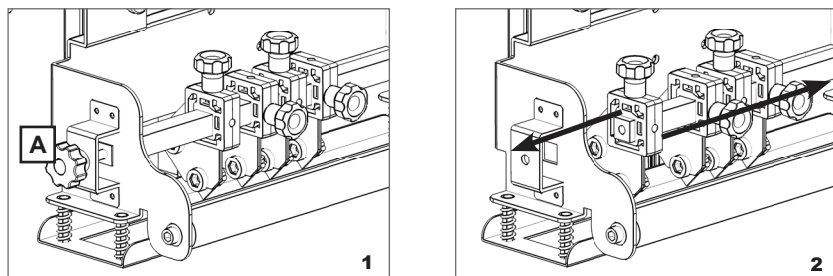

1. Release the knob (A) to remove the supporting iron bar
2. Slide in the additional blade holder or slide out the unnecessary one.  
Reinstall the supporting iron bar and tighten the knob.

## **How to rotate or replace the razor blade**

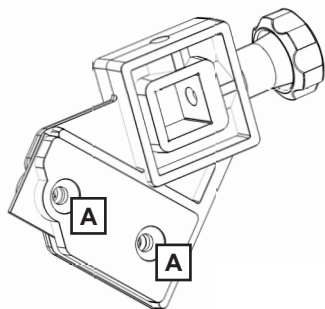

1. Remove the two screws (A), the small iron support holding the blade in place comes off.

2. Rotate or replace the blade.

*This razor blade offers four cutting corners, when a cutting corner is worn out, it is possible to rotate the blade and expose a different cutting corner before having the blade completely replaced!*

3. Screw back the small iron support to fix down the blade in place

### **How to cut the external trims**

Use the slitter module to cut the external trims. This will allow you to remove it along with the waste.

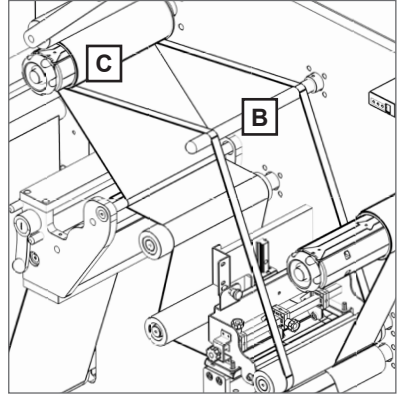
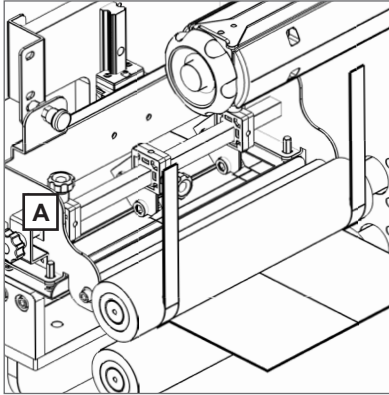

Tighten the knob (A) to lock the blade holder in the desired position.

Route the external trims over the roller (B) and secure it to the waste rewinder (C).

### **Two different ways to remove the waste**

You have two ways to remove waste material from the unit. Using roller (figure 1) or the bar (figure 2). This is all dependent on the type of materials being used, the type of laminate used, and the shape of the die-cut.

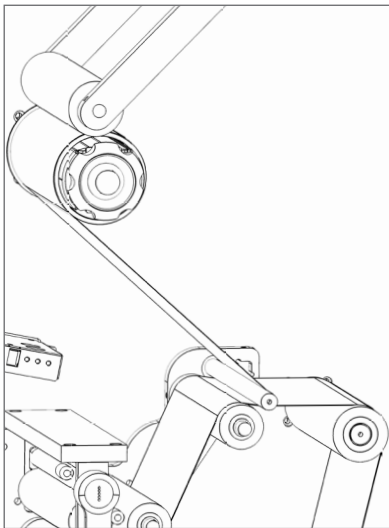

*Figure 1*

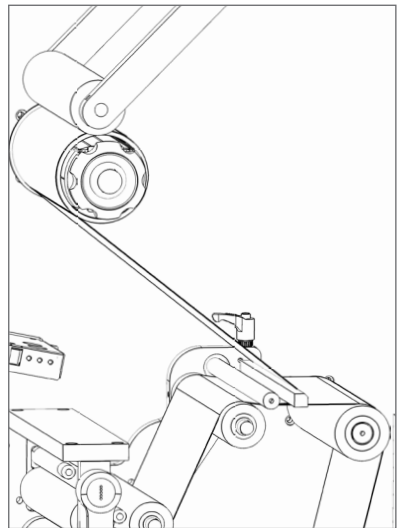

*Figure 2*



# EQUIPMENT

DLP-2200 unit is assembled by two modules, levelled and fixed together:

## UNWINDER MODULE

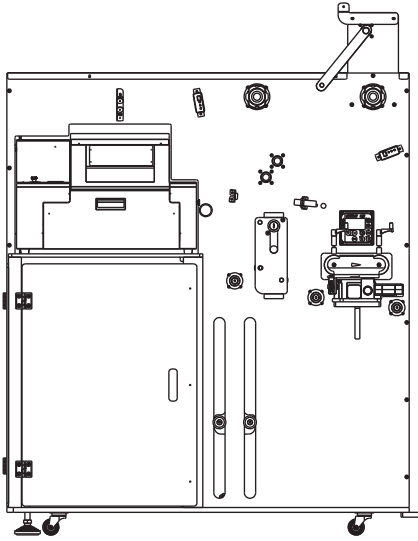

## ROTARY & REWINDER MODULE

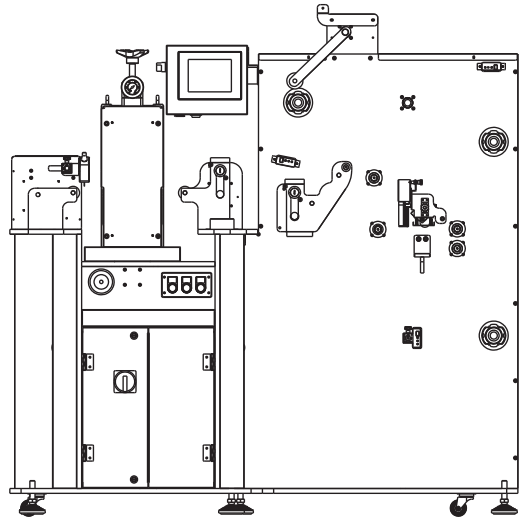

### **!IMPORTANT!**

*The two modules are properly levelled and aligned together for correct operation.*

*DO NOT move the unit by yourself, you might compromise the working operation. Please contact Technical Support before taking any action.*

# UNWINDER MODULE

Module used to load the continuous unprinted or printed roll of media, it is equipped with mechanical or pneumatic shafts depending on the selected version.

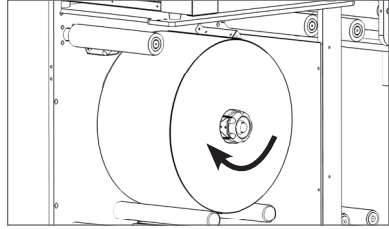
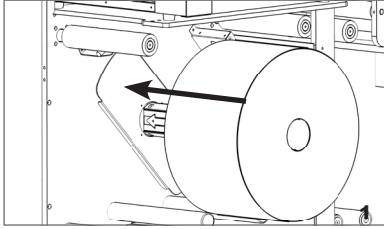

Load the input media roll on to the shaft and tighten the knob to get the roll fixed.

Each core holder is managed by its own controller designed to set the required media tension, keeping that tension automatically constant even the roll diameter variation during the job.

## Laminator and liner controller

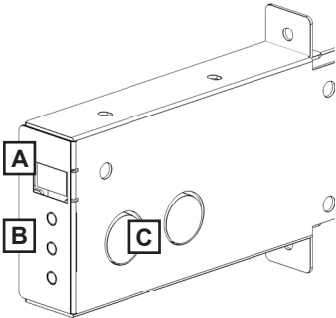

- A) Display
- B) **ON/OFF** : activate/deactivate the tension control
  - + : increase the media tension
  - : decrease the media tension
- C) Ultrasonic sensor

### Display conditions:

- flashing 0 - F - F = the controller is deactivated
- flashing number = the controller is active and it shows the tension level set

Keeping “run” pressed; the core will spin

## Unwinder controller

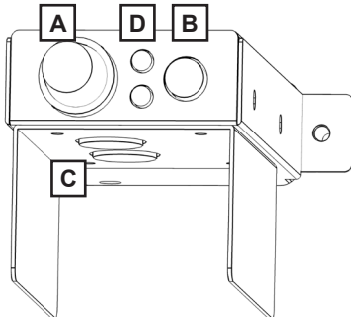

- A) Potentiometer activates or deactivates the core and it sets the media tension intensity
- B) Button to manually rewind the roll backwards
- C) Ultrasonic sensor
- D) Yellow LED is ON; controller deactivated  
Green LED is ON; controller activated

Afinia Label Printer

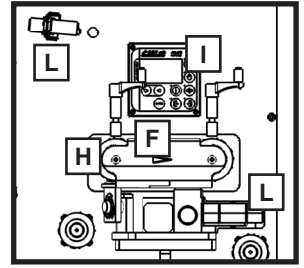
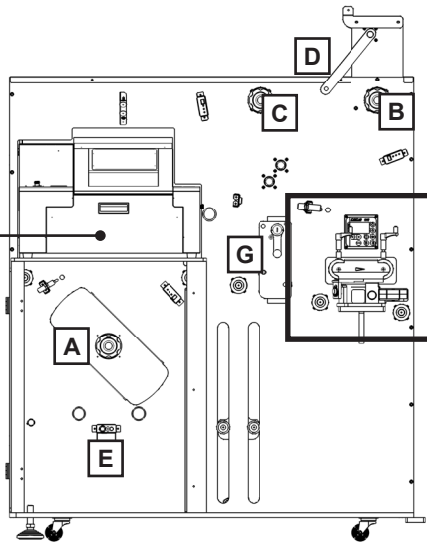

This module offers the opportunity to apply adhesive cold self-wound or with liner lamination.

**A)** Core holder designated to load the input media roll.

**B)** Core holder designated to load the lamination roll.

**C)** Core holder designated to rewind the lamination's liner.

**D) *Silencer accessory*** used to drastically reduce the noise generated during the application of noisy self-wound lamination roll.

**E) *Media sensor*** to stop the unit immediately when the media runs out.

**F) *Splice Table*** joins the finished roll to the new roll easily; it helps to save time and waste of media during the changing roll operation.

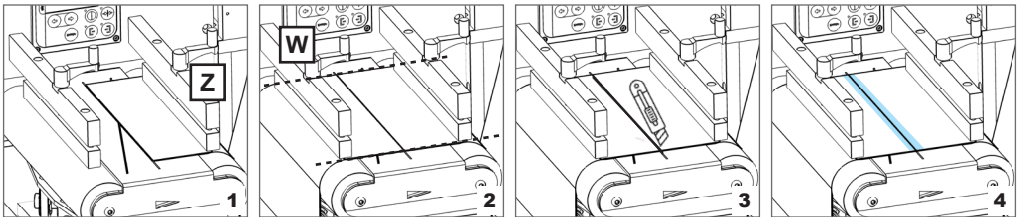

**1.** Screw the knob (Z), the bracket fixes down the media already loaded through the unit

**2.** Align the media from the new input roll just loaded to the media inside the unit and screw the knob (W). The bracket fixes down the new media too.

**3.** With cutter, cut the excess media along the lines.

**4.** With tape join both ends together (under and over the media) and release both knobs.

**G) Nip Roller** assembly used to lock and forward the media through the system when the lever is set to “close” position. When the lever is set to “open” the media is unlocked and unable to be pulled by the system.

**H)** Web guide used to keep the media path straight and aligned through the unit.

**I)** Web guide controller.

**L)** Web guide sensor.

**M) Lamine sensor.**

### **MEDIA SENSOR**

- When media is loaded, the orange LED is on.

- When media runs out (or media is not loaded), the orange LED turns off and it stops the unit.

### **HOW TO SET THE MEDIA SENSOR**

With media properly loaded, keep the small button pressed for a few seconds.

The orange LED flashes, release the button. It turns off and on. The sensor is set.

### **LAMINATE SENSOR**

- When laminate is not used, keep cap installed on the sensor. The orange LED is off.

- When laminate is loaded, remove the cap. The orange LED is off.

- When laminate runs out or is not loaded, the orange LED is on.



### **!!IMPORTANT!**

*If the laminate is not loaded and the cap is not installed, the orange LED is ON and it keeps the system in error. Every time a new type of laminate is loaded; it is recommended to reset the sensor.*

### **HOW TO SET THE LAMINATE SENSOR**

With laminate properly loaded, turn the small screw until the orange LED is OFF.

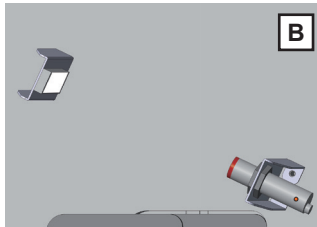
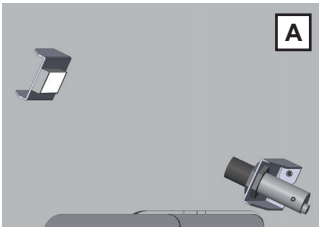

**A. SENSOR WITH CAP OR WITH LAMINATE LOADED:  
ORANGE LED OFF**

**B. SENSOR WITHOUT CAP OR WITHOUT LAMINATE:  
ORANGE LED ON**



### **!!IMPORTANT!**

*Every time a roll is loaded on to the core, remember to activate the controller by setting the tension intensity through the potentiometer's clockwise rotation.*

## WEB GUIDE

In automatic mode, the edge sensor detects the current position (actual position) of the material web and transmits the respective information to the integrated controller.

The controller compares the actual recorded position against the default position. The controller will send a relevant correction signal to the actuator if a deviation is found to exist between the two values.

The actuator pivots the movable pivoting frame suspended on the housing of the compact web guide control around a rotating point in the material web infeed until the material web is located back in its default position at the outfeed.

## REMOTE CONNECTION

The device, equipped with integrated Wi-Fi connection, can (with operator authorisation), be connected remotely through TeamViewer desktop remote access application to perform the remote technical support.

---

## **ROTARY & REWINDER MODULE**

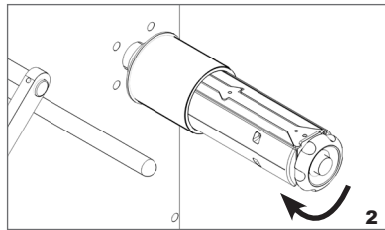
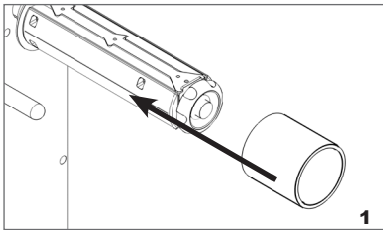

Load the media roll on to the shaft and tighten the knob to secure the roll.

Load the media roll on to the shaft and through the air gun, expand the pneumatic core to secure the roll.

Each core holder is managed by its own controller designed to set the required media tension, keeping that tension automatically constant even with roll diameter variation during the job.

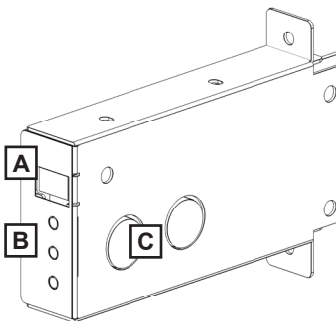

**A)** Display

**B) ON/OFF** : activate/deactivate the tension control

+ : increase the media tension

- : decrease the media tension

**C)** Ultrasonic sensor

Display conditions:

- flashing O - F - F = the controller is deactivated

- flashing number = the controller is active and it shows the tension level set

Keeping “run” pressed; the core will spin

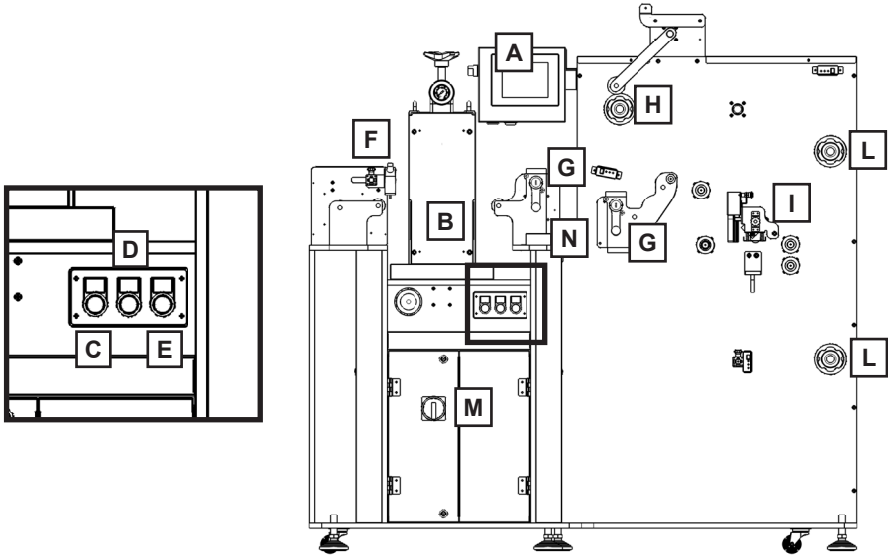

**A) Integrated touchscreen PC** with the DLP-2200 cutting software manager installed, as a user-friendly application developed to manage the cutting process.

**B) Semi-Rotary module.**

**C) Ready light** that indicates that the unit is ON.

**D) Power OFF button.**

**E) Power ON button.**

**F) Mark sensor** used to synchronise the cutting position on printed roll.

**G) Nip Roller assembly** used to lock and forward the media through the system when the lever is set to “close” position, while when the lever is set to “open” position the media is unlocked and unable to be forwarded by the system.

**H) Core holder** designated to rewind the removed waste.

**I) Longitudinal slitter assembly**, with the option to load up to 7 blade holders, it splits longitudinally the input media into narrower widths and each one is rewound on its own cardboard core.

The blade holder is equipped with a razor blade (0.2mm thickness). This blade features four shape corners, before having it replaced, it can be rotated on itself up to four times when a cutting side is worn out.

**L)** Double shaft designated to rewind the finished job. They can work individually or both at the same time.

**M)** Main ON/OFF Switch.

### **N) Offset Adjustment**

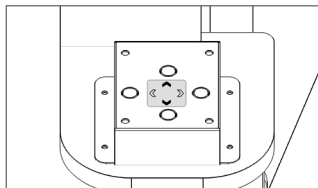

Black arrows  
ROTARY MODULE

These buttons move the rotary module along the width of the substrate.

White arrows  
BLACK-MARK SENSOR

These buttons move the black mark sensor left or right along the length of the substrate.



### **!!IMPORTANT!**

*Every time a cardboard core is loaded on to the shaft, remember to activate the controller by setting the tension intensity through the button on it.*

### **MARK SENSOR**

The mark sensor synchronises the cutting position on the printed media through the black mark reading. This device works with default default settings. In case of any issue, please reset it following the the instructions below.

### **DEVICE RESETING**

1. Press and hold the + and - push-buttons for 10 seconds.

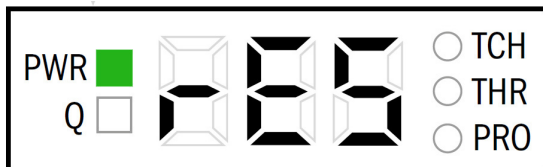

2. The set parameters are reset to the factory settings.

# HOW TO CALIBRATE THE MARK SENSOR

1. Press the button "SET" on the sensor. The sign "tch" shall appear.



2. Press again "SET". The sign "2P" shall appear.

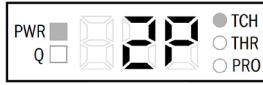

3. Press again "SET". The sign "1St" shall appear.



4. Now on the DLP-2200 software, press the button "FORWARD MEDIA", and stop once the sensor light is exactly on the mark.

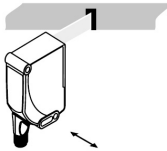

5. Press "SET" again on the sensor. The sign "2nd" shall appear.



6. From the DLP-2200 software press "FORWARD MEDIA" until the sensor light is no longer on the mark.

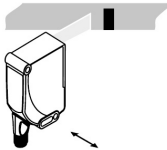

7. Press "SET" again on the sensor.

If the procedure was successful the sensor light will change to red, and it will display a score from 1 to 100 with the quality of the calibration.

If any error occurs, the "Err" sign will be displayed.



61 - 100	😊
31 - 60	😐
1 - 30	😞





# CUTTING MANAGER SOFTWARE

The cutting manager software comes already installed on the touchscreen and it will be used to perform all the operations on DLP-2200.

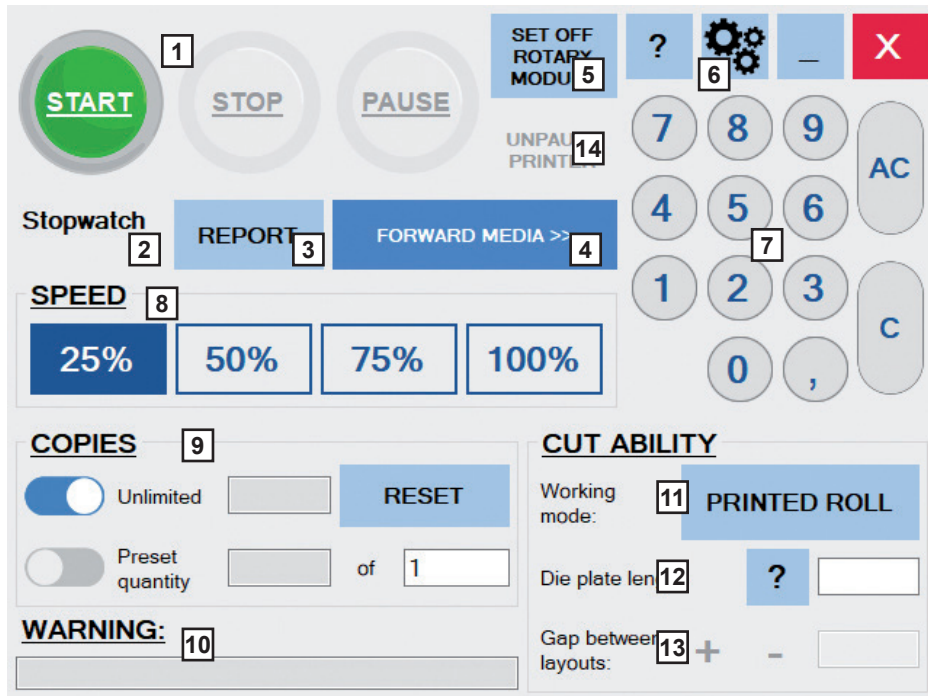

- 1) Controls for the start or the interrupting of the job.
- 2) A stopwatch that shows the expired time at the end of the job.
- 3) It opens the working report showing information for each job performed.
- 4) To forward the media without cutting.
- 5) It sets off the whole rotary module, unblocking it to allow the change of die plate.
- 6) It opens the **SETTINGS** window.
- 7) Pad number.
- 8) To set the operating speed of the material.

## 9) Copies

**UNLIMITED:** the unit will cut until the media roll runs out or, when using printed media, the sensor does not detect any black mark.

**PRESET QUANTITY:** the unit will cut the required quantity of layouts.

The “**RESET**” button is used to restore the amount of copies done for the current job.

10) Communication box shows warnings to the operator.

11) Choose the working mode

- INLINE PRINTER**: work while using the rotary and the inline printer simultaneously
- PRINTED ROLL**: cut on a printed roll (in this case the roll has already been made, so the inline printer is not used)
- FULL ROTARY**: cut on unprinted material, while working in full rotary mode (so not semi-rotary)
- UNPRINTED ROLL**: cut on unprinted material in semi-rotary mode.

12) Set the die plate length. Here a picture shows how to do it (this image can be checked even from the “?” button).

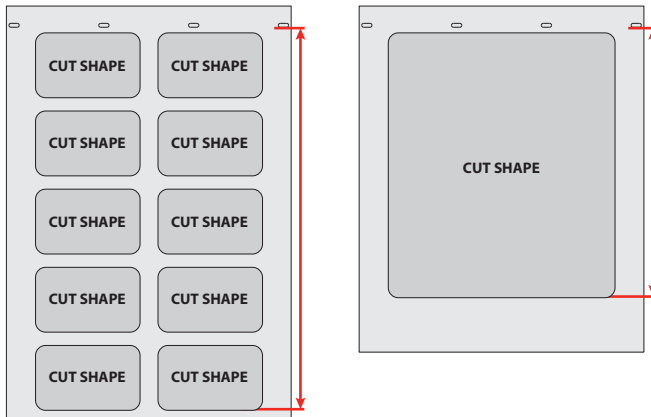

13) Set the distance between each label layout while printing on unprinted roll.

14) This button is used to enable the printer and allow the loading of the roll.

## SETTINGS

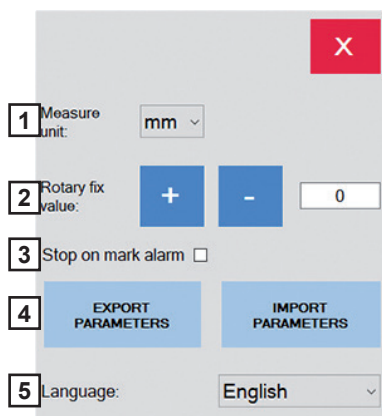

- 1- Measure unit: "Choose between mm and inches".
- 2- It determines the ratio between the rotation of the rotary, and the advancement of the material. This can be useful in case the length of the die-cut doesn't match the one of the printed layout (so in case the ratio is wrong, or the print is distorted).
- 3- Stop on mark alarm: "If enabled when the mark is not found the machine stops".
- 4- Export/import parameters: Allow to create or load a library with all the job's parameters.
- 5- Set the language for the software.

### Rotary fix value Demo



#### Negative Value

VERIFY THE CORRESPONDENCE OF THE CUT WITH THE PRINT.  
IF YOU NEED TO STRETCH THE CUT INSERT A NEGATIVE VALUE.

Start

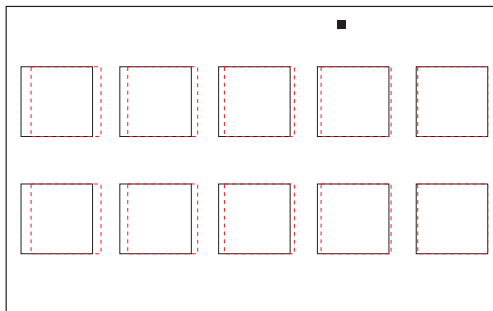

Finish

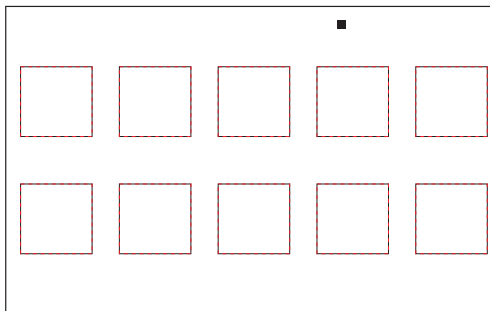

#### Positive Value

VERIFY THE CORRESPONDENCE OF THE CUT WITH THE PRINT.  
IF YOU NEED TO COMPRESS THE CUT INSERT A POSITIVE VALUE.

Start

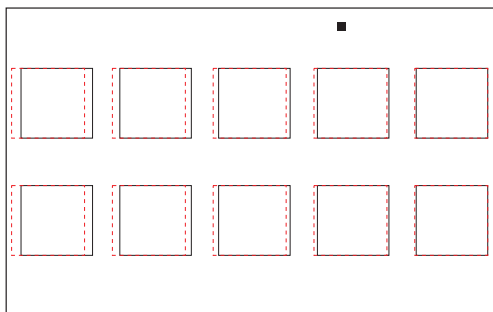

Finish

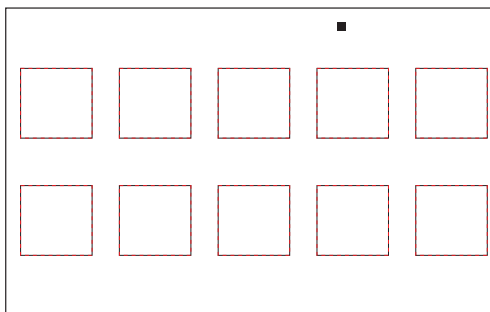

## **OFFSET ON THE FLY**

This feature allows the operator to adjust the offset layout while the unit is working at the minimum working speed only.

Select a preset or custom movement value in millimeters, applied in the direction of the pushed buttons.

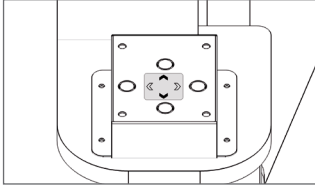

Black arrows  
ROTARY MODULE

These buttons move the rotary module along the width of the substrate.

White arrows  
BLACK-MARK SENSOR

These buttons move the black mark sensor left or right along the length of the substrate.

## **HOW TO CUT BLANK LABELS**

1. Select “Unprinted Roll”.
2. Set the gap between each layout.
4. Click “Start” to process the job of unlimited or preset blank labels.

## **CUT REPORT**

This menu shows the report of the jobs run on the device with the opportunity to save/export it as .txt file.

Moreover, it shows the working hours since the unit has been installed.

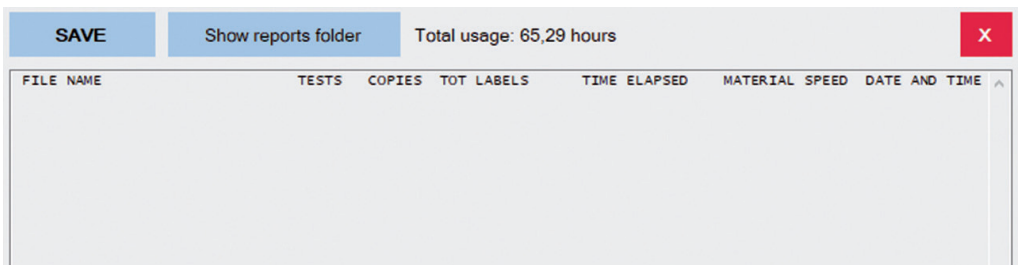

# HOW TO SET WEB GUIDE



On the control panel all control and display elements to manage the operation of the web guiding system are shown.

Below are the only two buttons used by the operator to switch the operation mode, from “centre positioning” required during the media loading to “automatic” once the media has been properly loaded through the system.

Function	Key	Designation	Description
Operating mode selection		<b>Automatic</b>	Automatic web guiding
		<b>Centre positioning</b>	Centre positioning of the guiding device

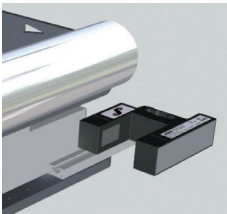

The edge sensor is properly set by the manufacturer, where (2) the centre of the sensor scanning area is aligned to the “zero point” media edge.

Below is the edge sensor status constantly displayed on the control panel, for correct operation, the numeric value (3) should not exceed  $\pm 4$ .

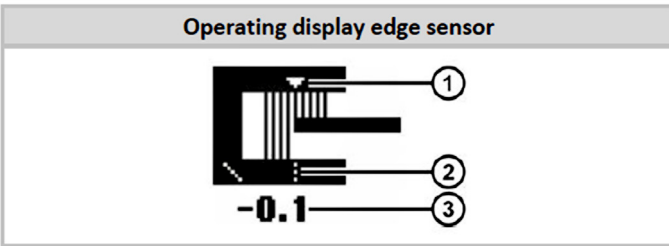

## Symbol meanings

①	The white triangle marks the set position of the web edge in the sensor scanning area.
②	The dashed line marks the centre of the sensor scanning area.
③	The numeric value indicates the current web edge position in the sensor scanning area (unit mm).

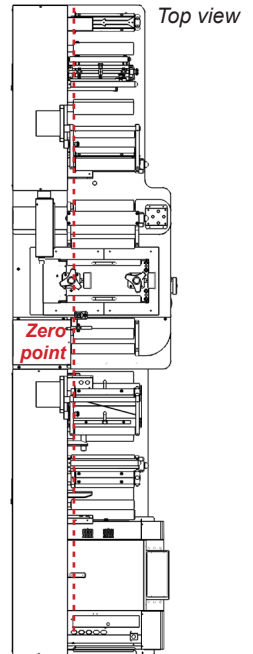

## **MEDIA LOADING**

1. All the core holder controllers must be off.
2. Set the web guide in “centre positioning” operating mode.
3. Fix an empty cardboard core (wide as media width to be used) on to the rewinder.
4. Load the input roll on to the Unwinder Core Holder.



### **!IMPORTANT!**

*it is mandatory to place the input media roll against the iron plate, it defines the media edge “zero point”.*

5. Keeping the nip roller modules open, pass the media through the unit following the diagram showing the media path.
6. Fix the media end to the empty core on to the rewinder core holder.



### **!IMPORTANT!**

*it is mandatory to tape the media while keeping the edge against the iron plate, to guarantee the media path alignment through the system.*

7. Close the nip roller modules.
8. Activate and set the core holders controllers.
9. Push “forward media” on touchscreen to check if the media has been loaded properly and straight.
10. If required, load the lamination. Pay attention to align it in the desired position.
11. Load the job and start the cutting process.
12. Once enough media has been cut, pause the job and peel off the waste and tape it on its dedicated core. Resume the job for a few more copies until the finished labels are rewound on the core.
13. If required, Pause the job to:
  - Set the back rotary blades to remove the external trims.
  - Set blade holders to split the input roll on multiple rows.
14. Resume the job.
15. Finally, pause the job and tape each row on to its own cardboard core.
16. Resume the job.

## PRINT FILE

Printing file length from 140 to to 360mm.

**4x4 black mark** is fixed at 140mm from the top of the artwork and 5mm from left side.

Print file includes:

- the graphics
- the black-mark



### !IMPORTANT!

*The printed input roll must be rewound as shown by the diagram in order to be properly managed by Taurus.*

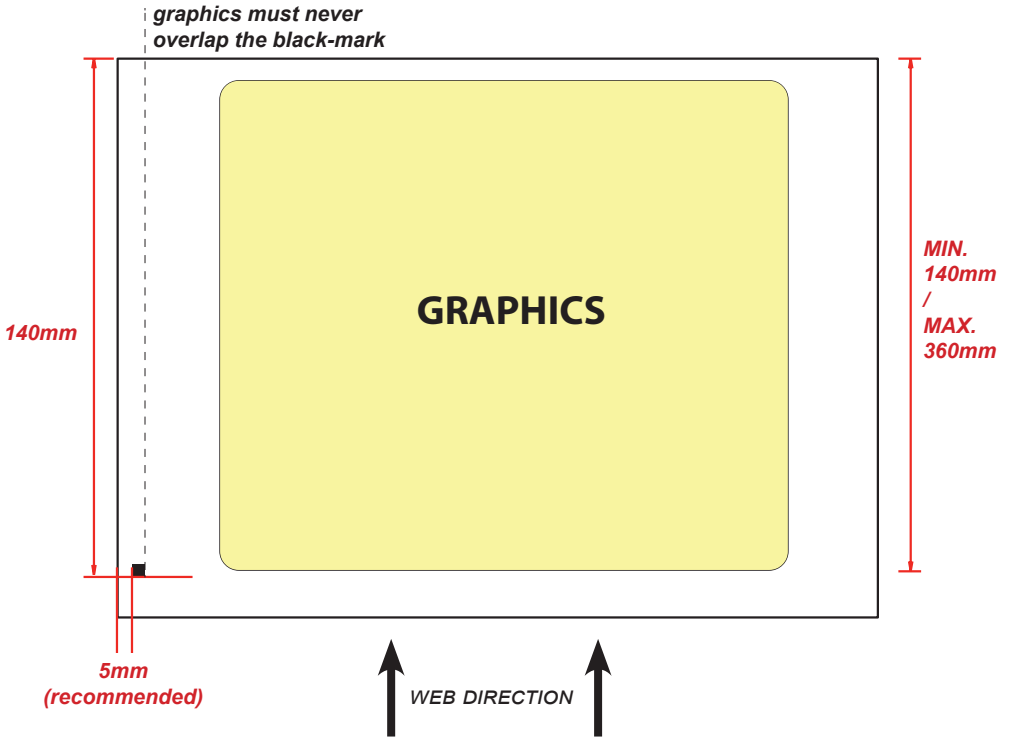
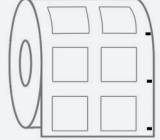

How to calculate the distance from the top and the bottom of your artwork file

**X: STITCH VALUE**

**Y: GAP**

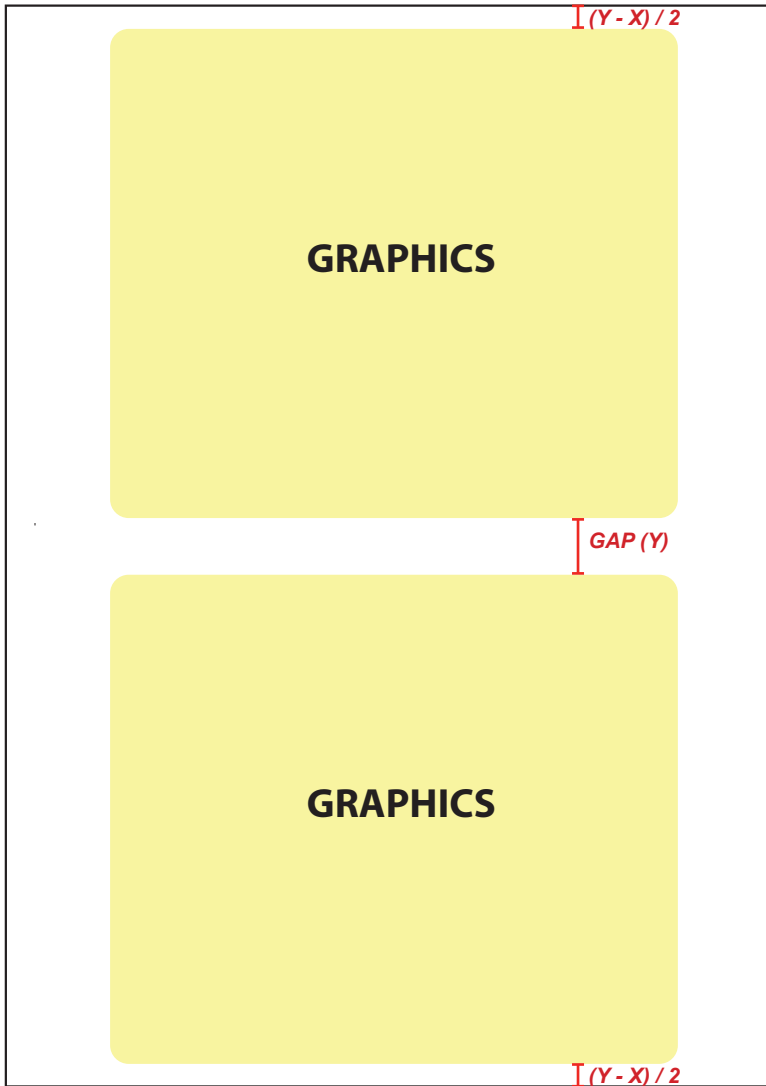



## **DIE PLATE**

Two button holes 3x8mm are mandatory/required.

Die plate width from 90 up to 222mm.

Die plate length from 156 to to 376mm.

Layout placed 4mm from the buttonholes.

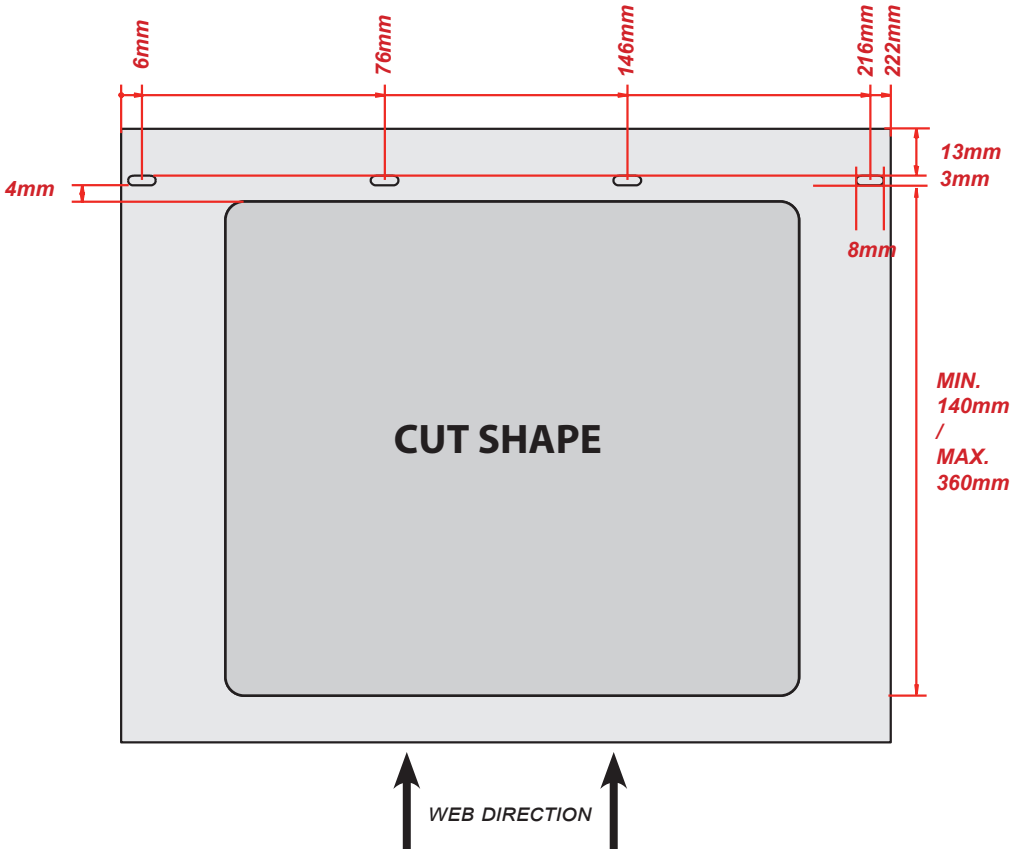

## **HOW TO INSTALL THE DIE PLATE**

1. Open the front plexiglass panel.
2. Fix the die plate with the 4 small holes on to the rotary cylinder.
3. Reinsert the front plexiglass panel.

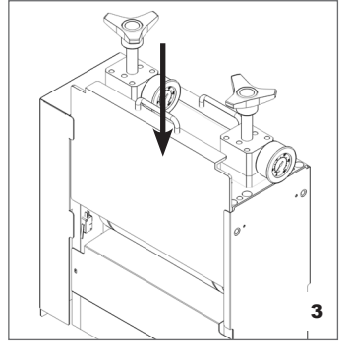
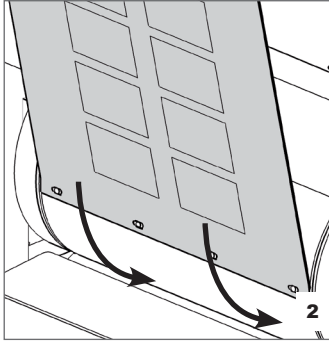
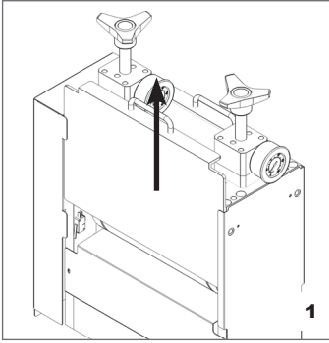

## **ROTARY CILYNDER**

Magnetic cylinder 18" - Z144 model 1/8  
Cylinder development 457.2mm

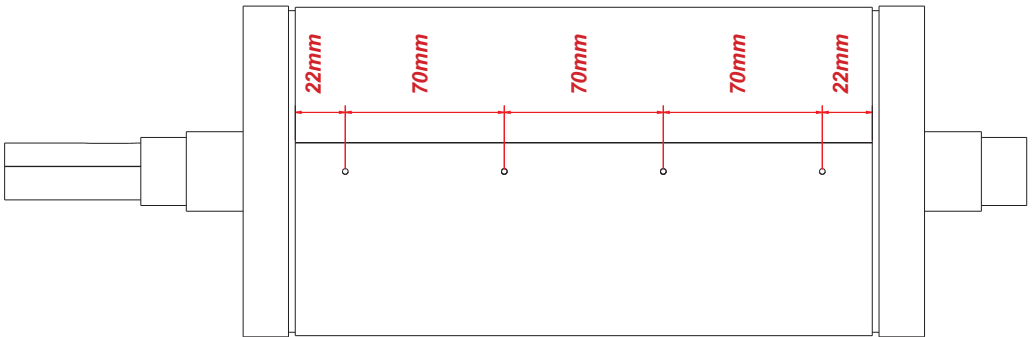

## **REGULAR MAINTENANCE**

Keep the nip rollers clean of glue.



### **!IMPORTANT!**

*Clean the unit using alcohol only, do not use chemical agents that might damage the unit.*

*Do not use blades to remove glue or sticky waste from the roller or any part of the unit.*

## ***SAFETY***

**DO NOT INSERT HANDS INTO THE NIP ROLLERS  
AND ROTARY MODULES**

**PAY ATTENTION TO THE SHAFTS WHEN OPERATING**